

# AA...C2 Differential Air Pressure Switch Installation Instructions



## SPECIFICATIONS

**AA...C2** SPDT Differential pressure switch in pressure and vacuum ranges. The differential pressure acts via the diaphragm against the force of the setting spring on the microswitch. The pressure switch operates without any auxiliary power.

**Gases**

Air and non-aggressive gases. **Not** suitable for natural gas, propane, butane and other combustible gases.

**Switch**

SPDT

**Switch action**

Pressure, vacuum or differential pressure switch.

**Contact Rating**

5 A resistive, 2.5A inductive @120 Vac

**Electrical Connection**

Screw terminals via 1/2" NPT conduit connection

**Enclosure**

NEMA Type 4

**Maximum Operating Pressure**

20 In W.C. (50 mbar)

**Ambient / Medium Temperature**

+5°F to +140°F (-15°C to +60 °C)

**Materials in contact with Gas**

Housing:	Polycarbonate
Switch:	Polycarbonate
Diaphragm:	NBR-based rubber
Switching contact:	Silver (Ag)

**Approvals**

UL Listed: File #.MH16628  
 CSA: Certificate #: 201527  
 FM Approved: Report J.1.0D6A1.AF  
 Commonwealth of Massachusetts Approved Product  
 Approval code G3-0106-191



## ATTENTION

- |   |   |
|---|---|
| <ul style="list-style-type: none"> <li>• Read these instructions carefully.</li> <li>• Failure to follow them and/or improper installation may cause explosion, property damage and injuries.</li> <li>• Installation must be done with the supervision of a licensed burner technician.</li> <li>• Check the ratings in the specifications to make sure that it is suitable for your application.</li> <li>• Never perform work if gas pressure or power is applied, or in the presence of an open flame.</li> <li>• Ensure that the switch is not subjected to vibration during operation.</li> </ul> | <ul style="list-style-type: none"> <li>• Once installed, perform a complete checkout including leak testing.</li> <li>• Label all wires prior to disconnection when servicing. Wiring errors can cause improper and dangerous operation</li> <li>• Verify proper operation after servicing.</li> <li>• The system must be installed, used, and maintained to meet all applicable national and local code requirements such as but not limited to NFPA 86, NFPA 160, ANSI Z83.4/ CSA 3.7, ANSI Z83.18/CSA 4.9, ANSI Z21.13, CSD-1, UL 795, CAN1-3.1, CGA 3.2, CSA 3.8, CSA B149.1, or CSA B149.3.</li> </ul> |
|---|---|

## MODELS DESIGNATIONS AND RANGES

Type	Version	Order No.	Setting range in. W.C
<b>AA-C2-4-...</b>	AA-C2-4-1	217-333A	0.08 - 0.60
	AA-C2-4-2	217-334A	0.16 - 1.20
	AA-C2-4-3	217-336A	0.40 - 4.00

# SWITCH HYSTERSIS AND PRESSURE CONNECTIONS

## Definition of switching hysteresis $\Delta p$

The pressure difference between the upper and lower switching pressures.

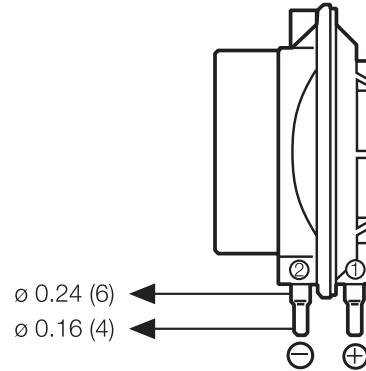
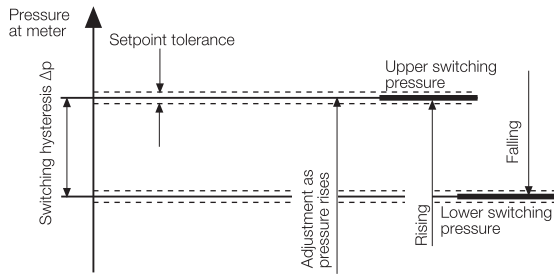

# APPLICATION AND CONNECTION EXAMPLES

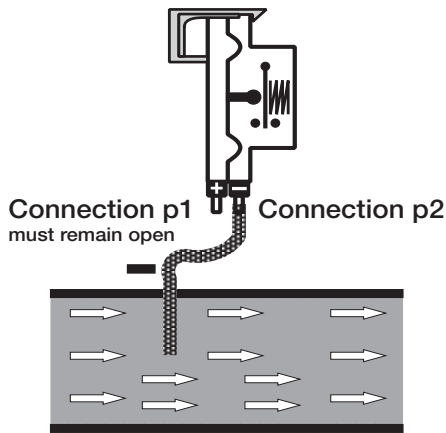

## System vacuum monitor

AA...C2 is connected to the air duct with the p2 (-) connection. p1 (+) is not connected with the air duct. Do not seal the p1 (+) connection; it must be open to the atmosphere.

Caution: Prevent dirt from entering into the device through connection p1(+).

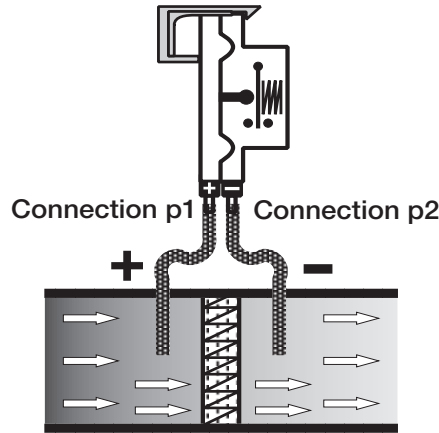

## Filter monitoring

To monitor a filter, the AA...C2 can be connected as shown above.

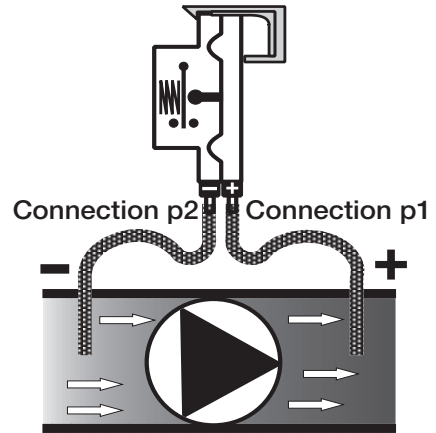

## Blower monitoring

For blower monitoring, connect connection p1 (+) to the air duct on the downstream side of the blower and connection p2 (-) to the air duct upstream of the blower.

**Always connect higher pressure to connection p1 (+).**

**Always connect higher vacuum to connection p2 (-).**

## Example of pressure connections

higher pressure:  
e.g. 3.5 in W.C.: connection p1 (+)  
lower pressure:  
e.g. 3 in W.C.: connection p2 (-)

## Example of vacuum connections

lower vacuum:  
e.g. -1 in W.C.: connection p1 (+)  
higher vacuum:  
e.g. -3 in W.C.: connection p2 (-)

## WIRING

- Remove the clear cover from the switch.
- Use 14 or 16 AWG wire rated for at least 75°C.
- Route the wires through the conduit connector.
- Connect the wiring to the appropriate screw terminals.
- Replace the clear cover.



**CAUTION:** All wiring must comply with local electrical codes, ordinances and regulations.



**CAUTION:** Do not exceed the switch ratings given in the specifications and on the switch.

### AA...C2 switching function

#### As pressure rises:

1 NC opens, 2 NO closes

#### As pressure falls:

1 NC closes, 2 NO opens

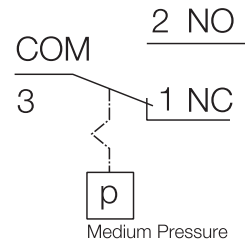

## OPERATION

### Adjusting the Set Point

- Mount switch in the intended operation position.
- Remove the clear cover from the switch.
- Adjust the set point to the desired set point pressure by turning the dial until the desired pressure is opposite the white arrow on the blue dial face.
- After adjusting the set point for normal operation check to see that the pressure switch operates as intended.

- Use an accurate pressure gauge connected upstream from the switch to measure the actual pressure.
- Replace the clear cover.

### Automatic Reset

The NC contact of the AA...C2 breaks when pressure rises above the set point. It makes automatically when pressure falls below set point.

## MAINTENANCE

### Annually check the switch for proper operation Set Point Calibration

- Connect a meter capable of reading +/- 0 ohms to the NC and COM contacts.
- Measure the resistance across the NC and COM contacts. If the resistance is more than 1 ohm, the switch should be replaced, since this indicates that the switch contacts are starting to either corrode or carbonizing.

- Apply appressure to the + air pressure connection, and confirm that the NC contact breaks when pressure rises above the set point and that the NO contact makes. the NC contact will make automatically when pressure falls below the set point pressure.
- Connect a meter capable of reading +/- 0 ohms to the NO and COM contacts.
- Measure the resistance across the NO and COM contacts. If the resistance is more than 1 ohm, the switch should be replaced, since this indicates that the switch contacts are starting to either corrode or carbonizing.

## ACCESSORIES

<b>Accessory</b>	<b>Order No.</b>
Klima-Set (Duct mounting kit)	217-897
Replacement cover	228-732
Mounting bracket (plastic)	230-273
120 VAC light mounting kit (orange)	231-772
24 Vdc light mounting kit (orange)	231-774
120 VAC light (green)	248-240 (for switches with light mouting kit 231-772 already installed)
Replacement PG 11 conduit adapter	220-566
DIN connector (female plug)	210-318
Male plug for DIN connector	219-659